

20' Dry Freight Containers

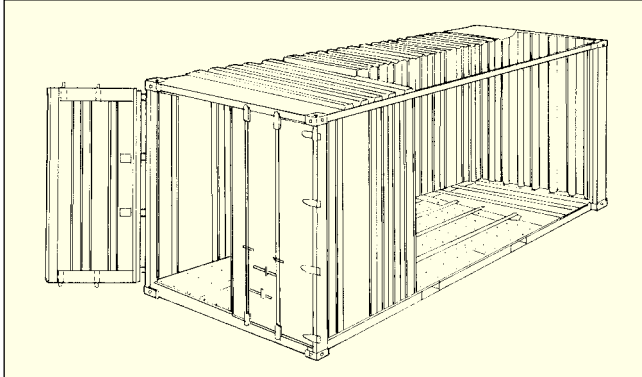

Height	Material	Tare Weight (kg/lbs)	Max* Cargo Cap. (kg/lbs)	Door Opening		Interior Dimensions			Interior Cube (m³/cft)
				Width (mm/ft)	Height (mm/ft)	Length (mm/ft)	Width (mm/ft)	Height (mm/ft)	
8'- 6"	Steel	2,300	21,700	2,340	2,280	5,905	2,350	2,392	33.2 1,172
		5,071	47,840	7' 8"	7' 6"	19' 4"	7' 9"	7' 10"	
8'- 6"	Steel	2,300	27,700**	2,340	2,280	5,905	2,350	2,392	33.2 1,172
		5,071	61,070**	7' 8"	7' 6"	19' 4"	7' 9"	7' 10"	

Remarks * : Subject to road and rail weight limitations.

** : Figures were changed from containers produced after July 1998.

: Above are typical figures for this type of containers.

40' Dry Freight Containers

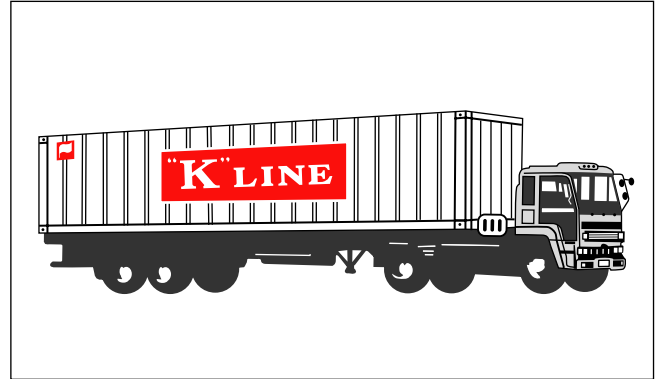
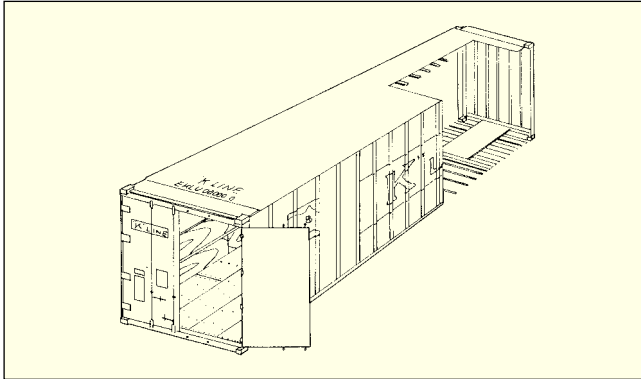

Height	Material	Tare Weight (kg/1bs)	Max* Cargo Cap. (kg/1bs)	Door Opening		Interior Dimensions			Interior Cube (m³/cft)
				Width (mm/ft)	Height (mm/ft)	Length (mm/ft)	Width (mm/ft)	Height (mm/ft)	
8'– 6"	Steel	3,860	26,620	2,340	2,280	12,039	2,350	2,392	67.7
		8,510	58,687	7' 8"	7' 6"	39' 6"	7' 9"	7' 10"	

Remarks * : Subject to road and rail weight limitations.
 : Above are typical figures for this type of containers.

40' HC Containers

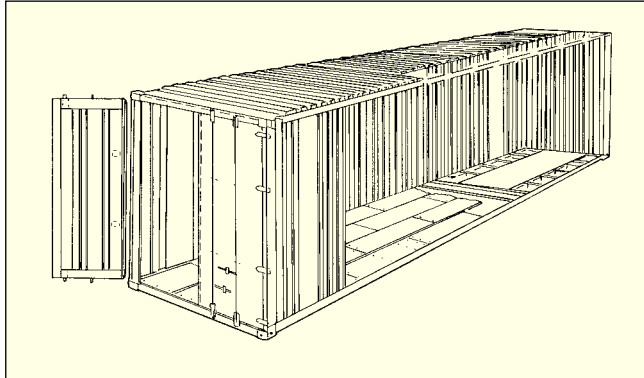

Height	Material	Tare Weight (kg/lbs)	Max* Cargo Cap (kg/lbs)	Door Opening		Interior Dimensions			Interior Cube (m³/cft)
				Width (mm/ft)	Height (mm/ft)	Length (mm/ft)	Width (mm/ft)	Height (mm/ft)	
9'- 6"	Steel	3,990 8,796	26,490 58,400	2,340 7' 8"	2,585 8' 6"	12,035 39' 6"	2,350 7' 9"	2,696 8' 10"	76.3 2,693

Remarks * : Subject to road and rail weight limitations.
 : Above are typical figures for this type of containers.

45' HC Containers

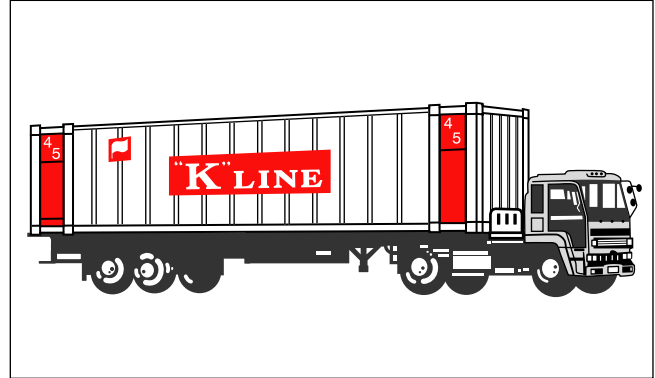
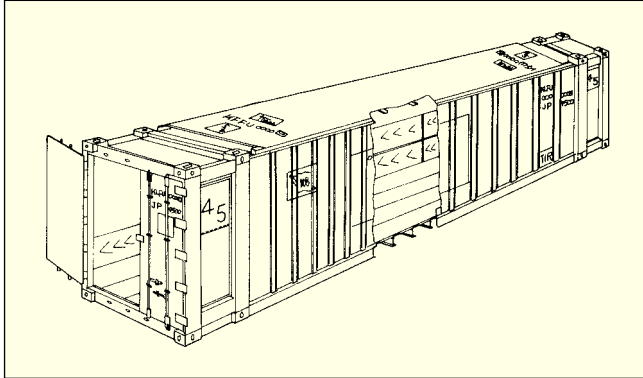

Height	Material	Tare Weight (kg/lbs)	Max* Cargo Cap. (kg/lbs)	Door Opening		Inter Dimensions			Interior Cube (m³/cft)
				Width (mm/ft)	Height (mm/ft)	Length (mm/ft)	Width (mm/ft)	Height (mm/ft)	
9'- 6"	Steel	4,850 10,693	25,630 56,504	2,340 7' 8"	2,585 8' 6"	13,558 44' 6"	2,350 7' 9"	2,695 8' 10"	85.9 3,045

Remarks * : Subject to road and rail weight limitations.
 : Above are typical figures for this type of containers.

20' Refrigerated Containers

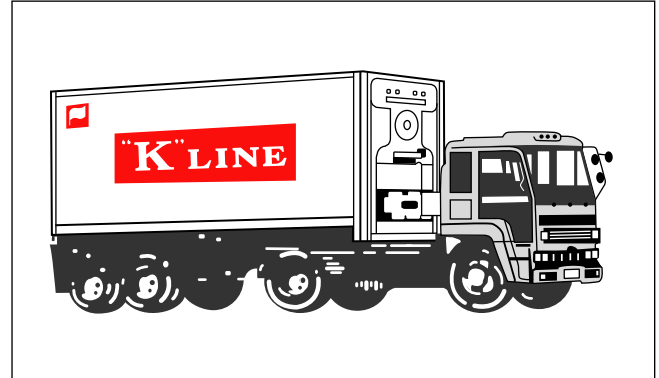
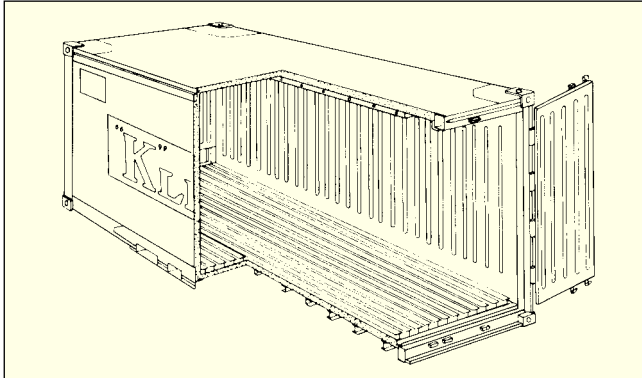

Height	Material	Tare Weight (kg/1bs)	Max* Cargo Cap. (kg/1bs)	Door Opening		Interior Dimensions			Interior Cube (m³/cft)
				Width (mm/ft)	Height (mm/ft)	Length (mm/ft)	Width (mm/ft)	Height (mm/ft)	
8'– 6"	Aluminium	2,820	21,180	2,252	2,212	5,545	2,252	2,259	28.2
		6,217	46,694	7' 5"	7' 3"	18' 2"	7' 5"	7' 5"	995
8'– 6"	MGSS	2,920	24,080	2,294	2,262	5,498	2,274	2,262	28.3
		6,437	53,086	7' 6"	7' 5"	18' 00"	7' 6"	7' 5"	1,002

Remarks * : Subject to road and rail weight limitations.
 : Above are typical figures for this type of containers.

40' Refrigerated Containers

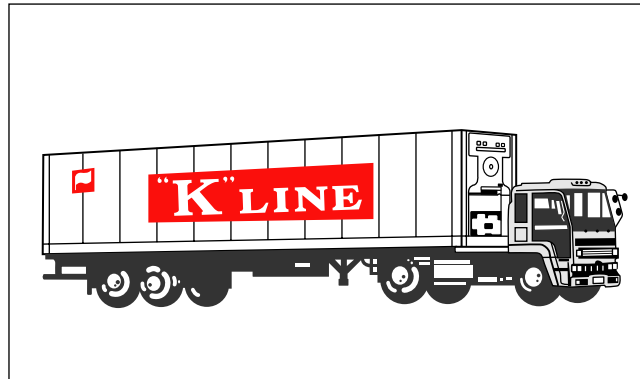
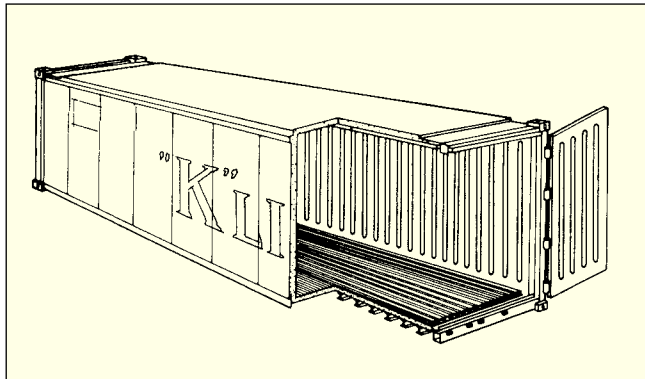

Height	Material	Tare Weight (kg/1bs)	Max* Cargo Cap. (kg/1bs)	Door Opening		Interior Dimensions			Interior Cube (m³/cft)
				Width (mm/ft)	Height (mm/ft)	Length (mm/ft)	Width (mm/ft)	Height (mm/ft)	
8'- 6"	Aluminium	4,100	26,380	2,286	2,169	11,679	2,286	2,211	59.0
		9,039	58,158	7' 6"	7' 1"	38' 4"	7' 6"	7' 3"	

Remarks * : Subject to road and rail weight limitations.

: Above are typical figures for this type of containers.

40' HC Refrigerated Containers

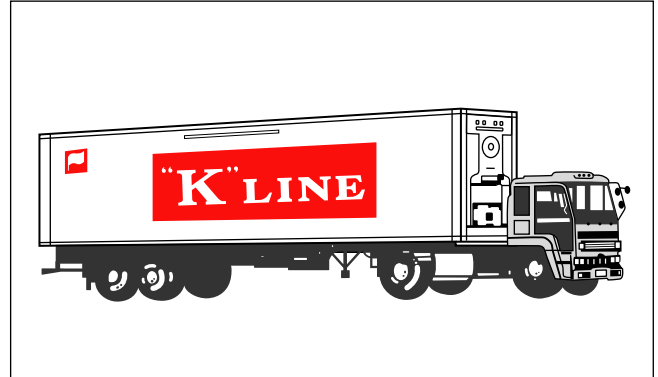
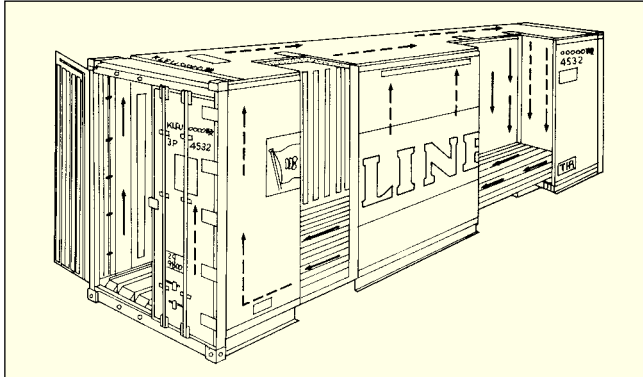

Height	Material	Tare Weight (kg/lbs)	Max* Cargo Cap. (kg/lbs)	Door Opening		Interior Dimensions			Interior Cube (m³/cft)
				Width (mm/ft)	Height (mm/ft)	Length (mm/ft)	Width (mm/ft)	Height (mm/ft)	
9'– 6"	Aluminium	4,550	25,930	2,286	2,443	11,672	2,286	2,505	66.8
		10,031	57,166	7' 6"	8' 0"	38' 4"	7' 6"	8' 3"	2,358
9'– 6"	MGSS	4,745	27,755	2,290	2,569	11,574	2,294	2,557	68.0
		10,461	61,188	7' 6"	8' 5"	38' 00"	7' 6"	8' 5"	2,400

Remarks * : Subject to road and rail weight limitations.

: Above are typical figures for this type of containers.

20' Open Top Containers

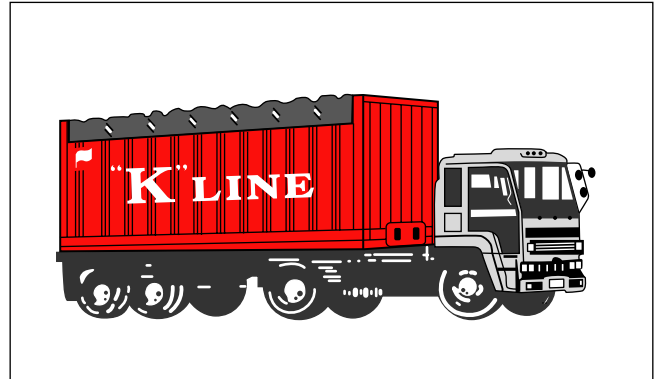
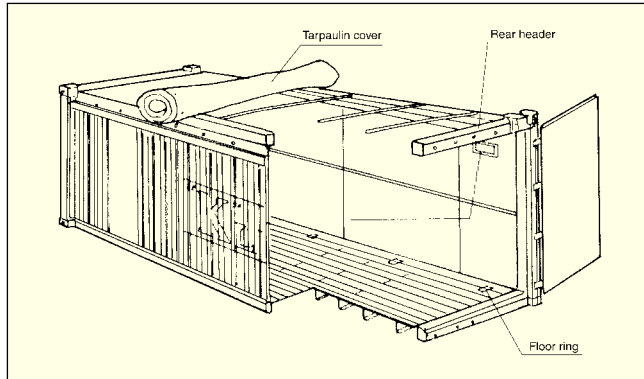

Height	Material	Tare Weight (kg/lbs)	Max* Cargo Cap. (kg/lbs)	Door Opening		Interior Dimensions			Interior Cube (m³/cft)
				Width (mm/ft)	Height (mm/ft)	Length (mm/ft)	Width (mm/ft)	Height (mm/ft)	
8'– 0"	Steel	2,450	21,550	2,338	2,234	5,891	2,350	2,330	32.2 1,137
		5,401	47,510	7' 8"	7' 4"	19' 4"	7' 9"	7' 8"	

Remarks * : Subject to road and rail weight limitations.
 : Above are typical figures for this type of containers.

40' Open Top Containers

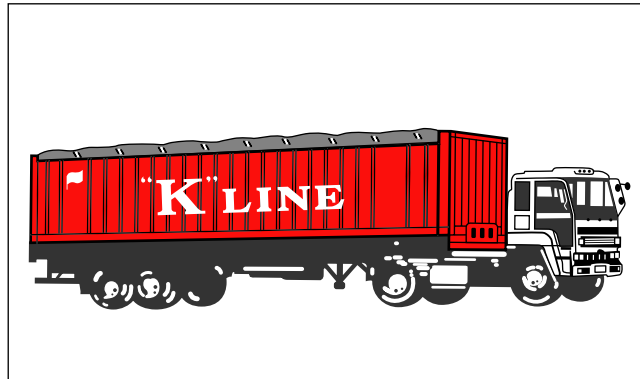
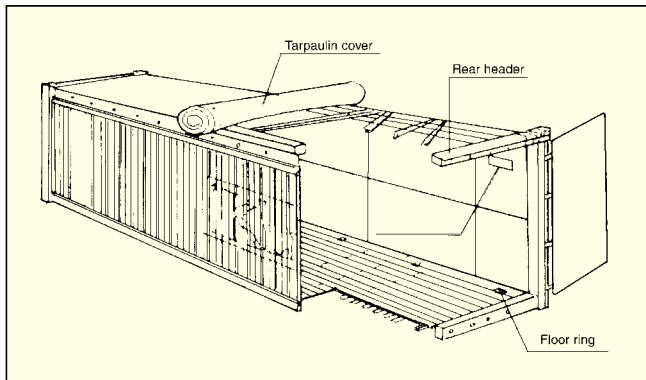

Height	Material	Tare Weight (kg/1bs)	Max* Cargo Cap. (kg/1bs)	Door Opening		Interior Dimensions			Interior Cube (m³/cft)
				Width (mm/ft)	Height (mm/ft)	Length (mm/ft)	Width (mm/ft)	Height (mm/ft)	
8'– 6"	Steel	4,150	26,330	2,338	2,234	12,025	2,350	2,330	65.8
		9,149	58,048	7' 8"	7' 4"	39' 5"	7' 9"	7' 8"	2,323

Remarks * : Subject to road and rail weight limitations.
 : Above are typical figures for this type of containers.

20' Flat Rack Containers

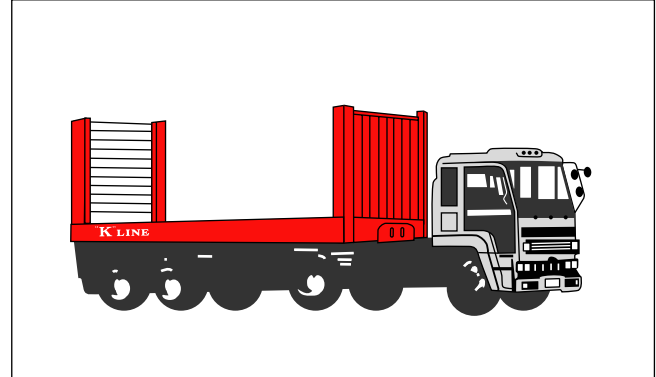
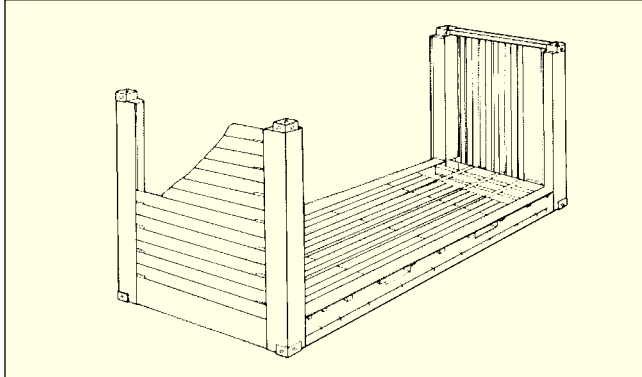

Height	Material	Tare Weight (kg/1bs)	Max* Cargo Cap. (kg/1bs)	Door Opening		Interior Dimensions			Interior Cube (m³/cft)
				Width (mm/ft)	Height (mm/ft)	Length (mm/ft)	Width (mm/ft)	Height (mm/ft)	
8'-6"	Steel	2,600 5,732	21,400 47,179	—	—	5,954 19' 6"	2,374 7' 9"	2,255 7' 5"	31.9 1,126

Remarks * : Subject to road and rail weight limitations.
 : Above are typical figures for this type of containers.

40' Flat Rack Containers

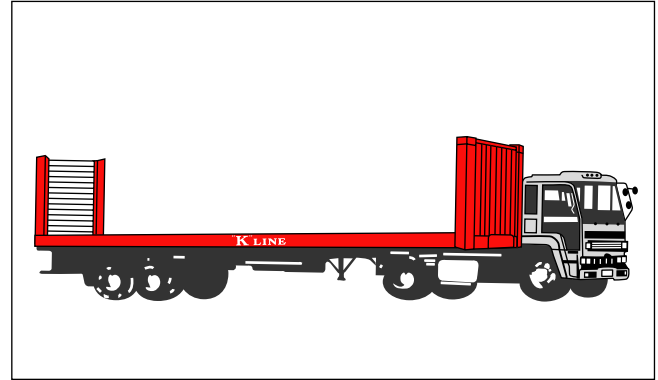
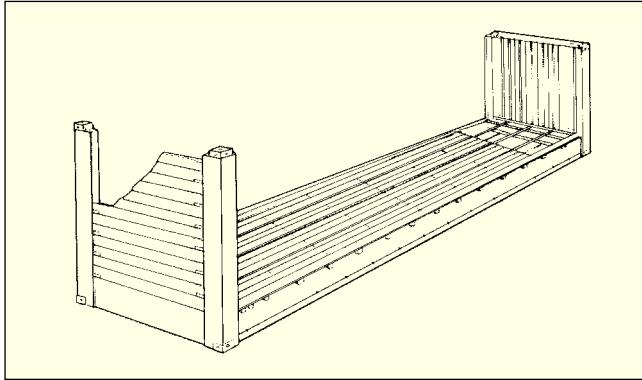

Height	Material	Tare Weight (kg/lbs)	Max* Cargo Cap. (kg/lbs)	Door Opening		Interior Dimensions			Interior Cube (m³/cft)
				Width (mm/ft)	Height (mm/ft)	Length (mm/ft)	Width (mm/ft)	Height (mm/ft)	
8'-6"	Steel	5,100	25,380	—	—	12,072	2,374	1,995	57.1
		11,244	55,953			39' 7"	7' 9"	6' 7"	

Remarks * : Subject to road and rail weight limitations.
 : Above are typical figures for this type of containers.

40' Plat Form

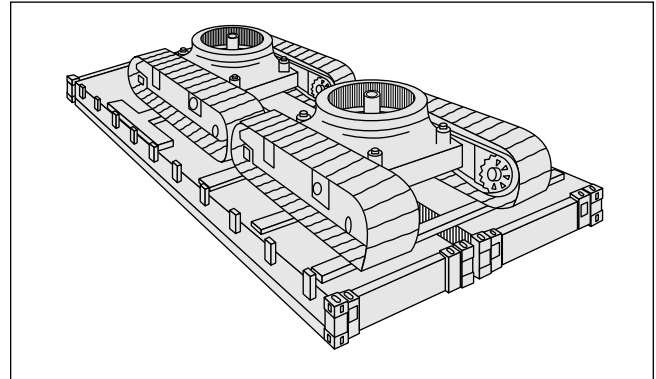
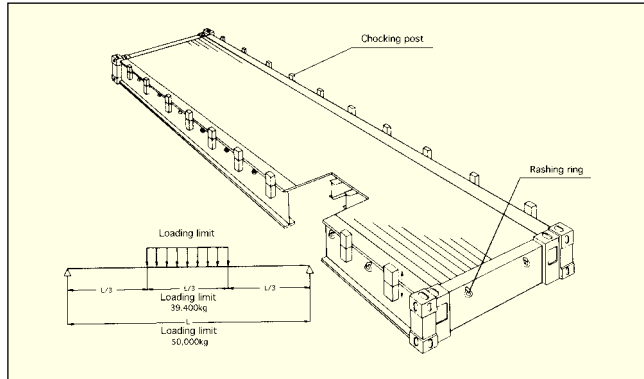

Height	Material	Tare Weight (kg/1bs)	Max* Cargo Cap. (kg/1bs)	Door Opening		Interior Dimensions			Interior Cube (m³/cft)
				Width (mm/ft)	Height (mm/ft)	Length (mm/ft)	Width (mm/ft)	Height (mm/ft)	
	Steel	6,160 13,580	50,000 110,231	—	—	12,192 40' 0"	2,438 8' 0"	—	—

Remarks * : Subject to road and rail weight limitations.
: Above are typical figures for this type of containers.